



p.u.k.[®]
Sistemi Professionali per Illuminazione



p.u.k.[®]



new items **2010**



p.u.k.[®]

new items **2010**

We would like to transmit,
through the use of our product,
our special policy aimed
at integrating the style
of our articles
with their surroundings.

In other words,
we want to communicate
our personal idea of “Light”.

Our products derive
from our policy
aimed at presenting
increasingly competitive
and better quality articles.

Our greatest wish
is to accomplish this policy.

HYDROLED IP65

PAGE 004



HYDROPOWER IP65

PAGE 012



HYDROFLOOR LED IP65

PAGE 016

PLANUS

PAGE 020



SPEEDSTER

PAGE 024



Hydroled **IP65**

HYDROLED 01



The image shows two identical light fixtures, labeled 'HYDROLED 02', mounted on a light-colored wall. Each fixture is a small, rectangular, white object. From the top of each fixture, a powerful, bright white beam of light is emitted, which then fans out into a wide, soft-edged cone of light. The background is a plain, light-colored wall. A white line connects the text 'HYDROLED 02' to the top of the fixture on the right, and another white line connects it to the top of the fixture on the left.

HYDROLED 02

An “Hi-Tech” design, ultra compact but powerful fixtures range. Ideal for indoor and outdoor applications, with limited mounting area or for accending delicate architectural or landscape details.



Hydroled 01

- Completely made of die cast aluminium
Integrated electronic components.
- Tempered safety glasses.
- Silicon rubber gaskets Phosphochromated
and polyester painting.
- The adjustable mounting bracket,
provides axis rotation for easy aiming.
- Ready to be installed 230V





LIGHT BEAM OPTIONS

-  SPOT 5°
-  FLOOD 40°

LIGHT COLOUR



-  COLD WHITE
-  BLUE

READY TO BE INSTALLED

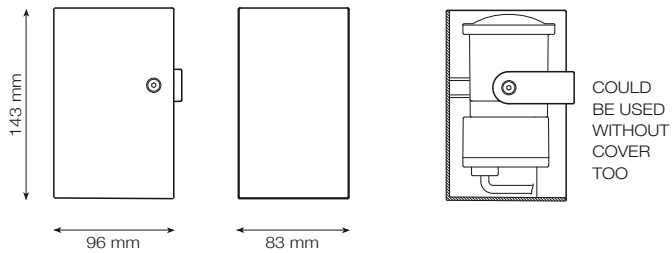
- LED 2 X 3 Watt
- 230 Volts led driver included
- IP65 - CE 
- 1,0 kg unit gross weight



AVAILABLE COLOURS

-  TEXTURE
-  MATT WHITE (ON REQUEST)
-  MATT BLACK (ON REQUEST)

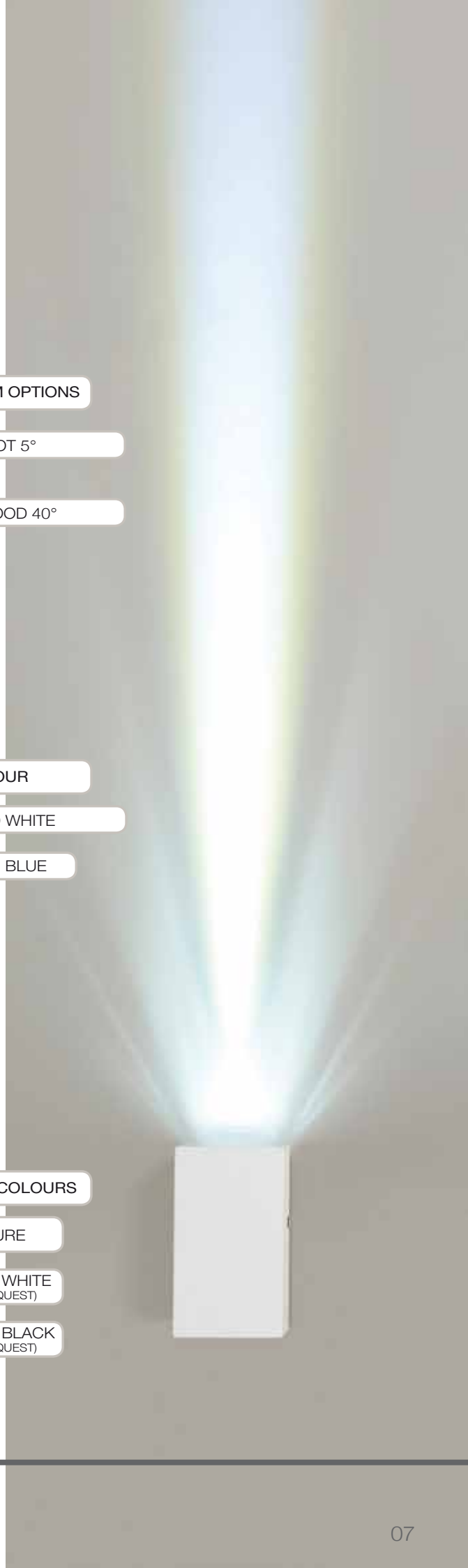
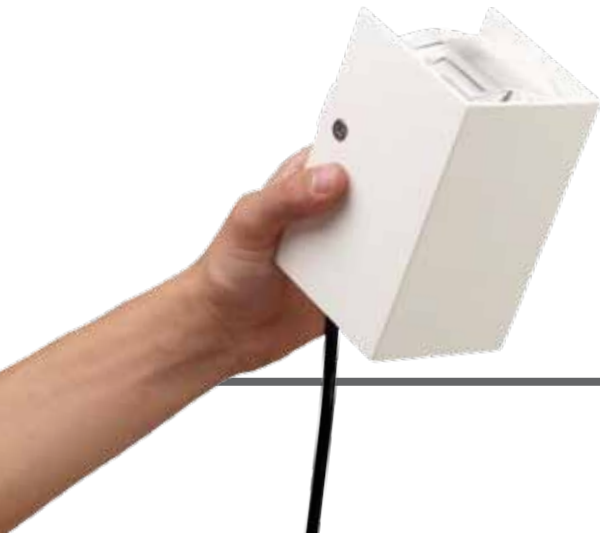



Hydroled **S**

- Completely made of die cast aluminium.
- Tempered safety glasses.
- Silicon rubber gaskets Phosphochromated and polyester painting.
- The adjustable mounting bracket, provides axis rotation for easy aiming.







LIGHT BEAM OPTIONS

-  SPOT 5°
-  FLOOD 40°

LIGHT COLOUR

-  COLD WHITE
-  BLUE

AVAILABLE COLOURS

-  TEXTURE
-  MATT WHITE (ON REQUEST)
-  MATT BLACK (ON REQUEST)

NEEDS EXTERNAL DRIVER

350mA

LED 2 X 3 Watt

IP65 - CE 

0,8 kg unit gross weight

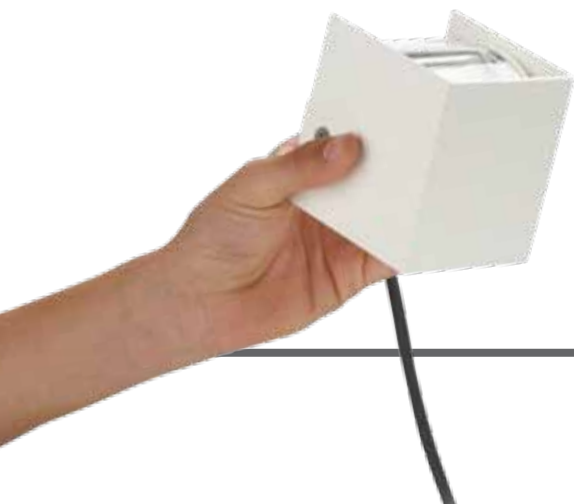
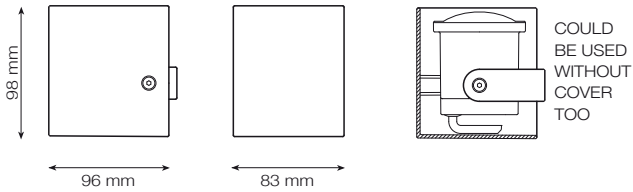

Hydroled 02

- Completely made of die cast aluminium
Integrated electronic components.
- Tempered safety glasses.
- Silicon rubber gaskets Phosphochromated
and polyestere painting.





LIGHT BEAM OPTIONS



SPOT 5°



FLOOD 40°

LIGHT COLOUR



COLD WHITE



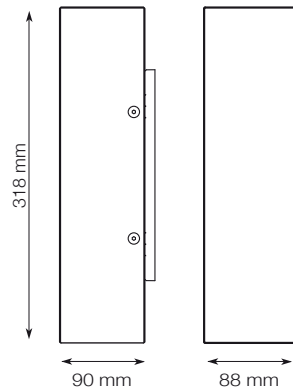

BLUE



READY TO BE INSTALLED

230 Volts Electronic

IP65 - CE  

2,3 kg unit gross weight

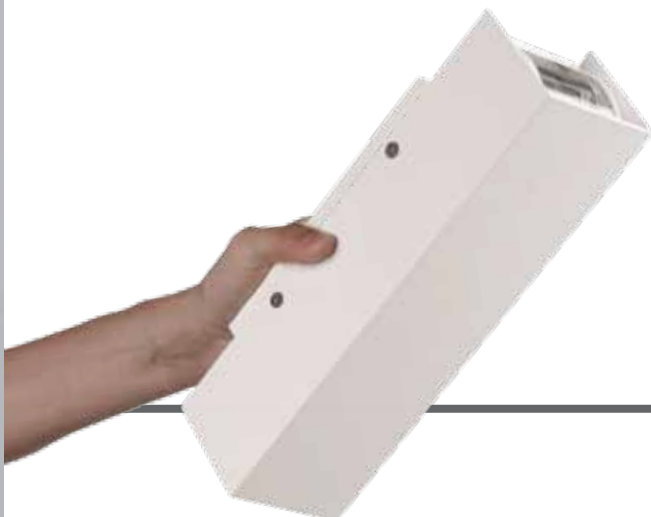

AVAILABLE COLOURS



TEXTURE



MATT WHITE
(ON REQUEST)



MATT BLACK
(ON REQUEST)

Hydropower **IP65**



HYDROPOWER IP65

Hydropower IP65

- Completely made of die cast aluminium Integrated electronic components.
- Tempered safety glasses.
- Silicon rubber gaskets Phosphochromated and polyester painting.

SUITABLE FOR:

- Small areas
- Lighting effects
- Lighting accents

Hydropower IP65

MINI 20

LIGHT BEAM OPTIONS



LIGHT COLOUR



AVAILABLE COLOURS



READY TO BE INSTALLED

20 Watt GU 6,5

230 - 240V HIT-TC-CE

IP65 - CE ▽ ⊕

1,9 kg unit gross weight

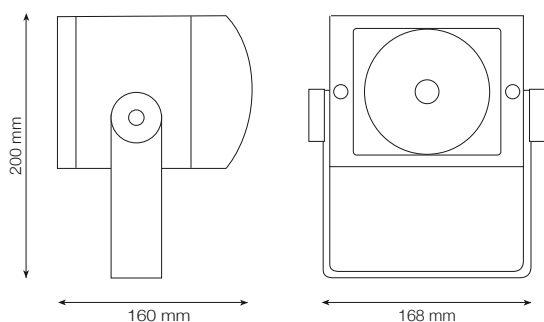

Hydropower IP65

- Completely made of die cast aluminium Integrated electric components.
- Tempered safety glasses.
- Silicon rubber gaskets Phosphochromated and polyester painting.

SUITABLE FOR:

- Medium areas
- Small buildings
- Bridges
- Tower

Hydropower IP65

MEDIO 70

LIGHT BEAM OPTIONS



LIGHT COLOUR



AVAILABLE COLOURS



READY TO BE INSTALLED

70 Watt G12

230V HIT-CRI

IP65 - CE ▽ ⊕

4,90 kg unit gross weight

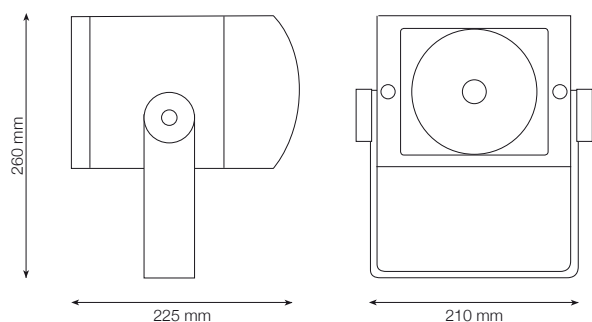



20 RADIAL LOUVRE

0,4 kg unit gross weight



70 RADIAL LOUVRE

0,5 kg unit gross weight



MINI 20 GRID

0,4 kg unit gross weight



MEDIO 70 GRID

0,5 kg unit gross weight





MEDIO 70 BARN-DOOR

0,2 kg unit gross weight

Hydropower IP65

OPTIONS

AVAILABLE COLOURS

-  TEXTURE
-  MATT WHITE
(ON REQUEST)
-  MATT BLACK
(ON REQUEST)

Hydrofloor Led **IP67**

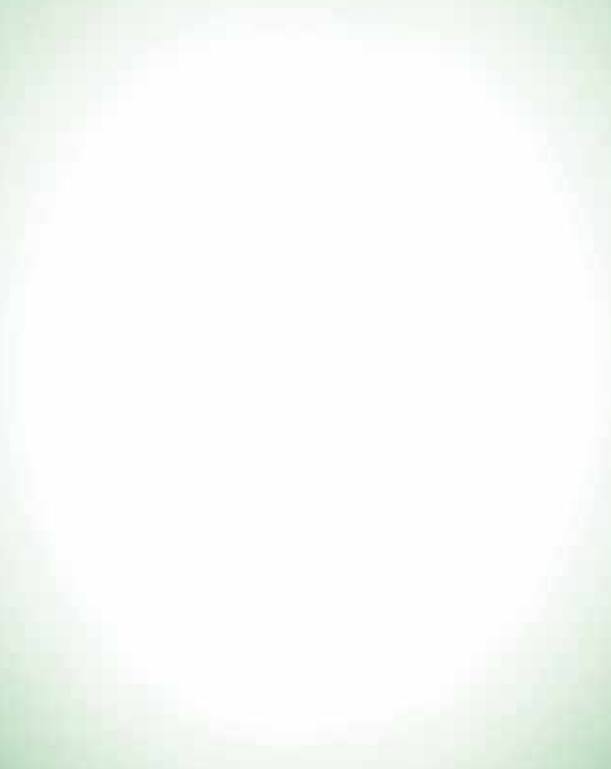

HYDROFLOOR LED IP67



Hydrofloor mini Led IP67

Until yesterday most of the lighting fixtures on L.E.D. technology could only be used as "signals" or "step lights" due to the fact that the emitted light was too low.

Super L.E.D. is the ultimate technology in light.

Today the new super L.E.D. technology can satisfy our most important need:

Light - You can do what, until yesterday, was simply impossible: have "visible and good light" with only 3 watts consumption.

These new fixtures were completely developed by P.U.K.

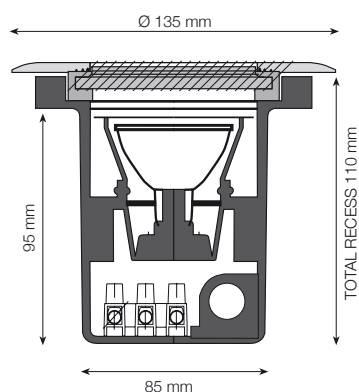

Hydrofloor Led IP67 MINI

LIGHT COLOUR

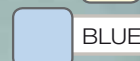
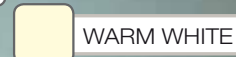

AVAILABLE COLOURS

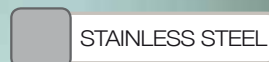

HYDROFLOOR MINI (L.E.D. 3W) "T" (ROUND)

READY TO BE INSTALLED

190 V ... 250 V/AC 50-60 Hz superled

Movable

3 meters silicone wire included

IP67 - CE

1,25 kg unit weight

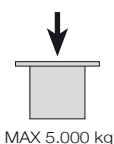

MAX 5.000 kg

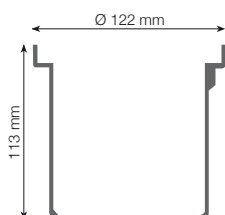

POLYPROPYLENE
HOUSING FOR RECESS
(INCLUDED)



THIS IS
A REAL PICTURE

Hydrofloor medium Led IP67

- High corrosion resistance die-cast aluminium body
- Polyester painting with phosphocromating pre-finish
- Stainless steel ring or frame AISI 304
- Stainless steel screws
- Conventional ballast 230V 50Hz
- **Silicone rubber gasket**
- **Max static weight resistance 5000 Kg**

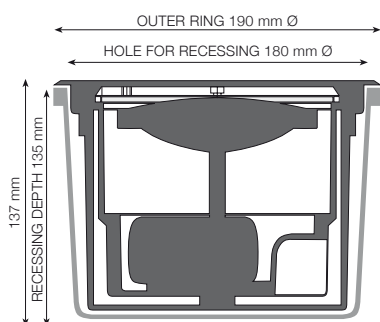

READY TO BE INSTALLED

6 Watt

230 Volts

IK09

Stainless steel ring

IP67 - CE ∇ \oplus

2,2 kg unit gross weight

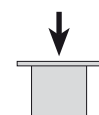

MAX 5.000 kg



Hydrofloor Led IP67 MEDIUM

LIGHT BEAM OPTIONS

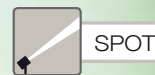

SPOT

LIGHT COLOUR



COLD WHITE



WARM WHITE

AVAILABLE COLOURS

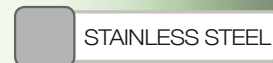

STAINLESS STEEL

THIS IS
A REAL PICTURE

Hydrofloor maxi Led IP67

- High corrosion resistance die-cast aluminium body
- Polyester painting with phosphochromating pre-finish
- Stainless steel ring or frame AISI 304
- Stainless steel screws
- Conventional ballast 230V 50Hz
- **Silicone rubber gasket**
- **Max static weight resistance 5000 Kg**
- **Double M20 cable grand**

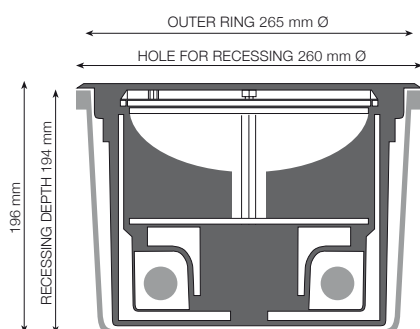

READY TO BE INSTALLED

12 Watt

230 Volts

Stainless steel ring

IP67 - CE 

5 kg unit gross weight

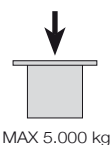
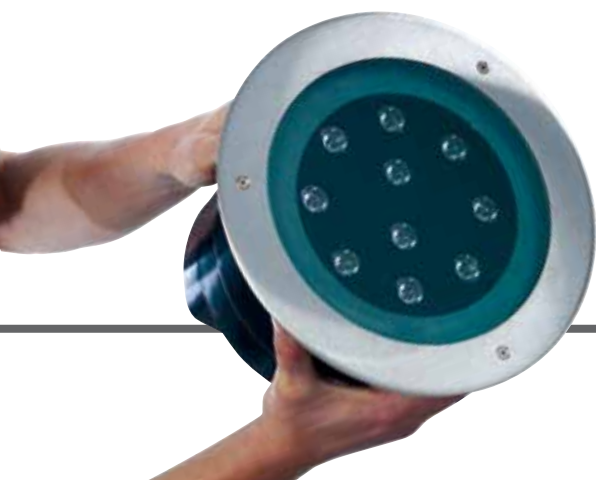

THIS IS
A REAL PICTURE

Hydrofloor Led IP67 MAXI

LIGHT BEAM OPTIONS



LIGHT COLOUR



AVAILABLE COLOURS

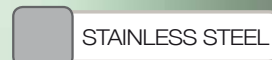

Planus



PLANUS

A new projector family for professional applications, as shop windows, store, museums and exhibitions areas. New original design, attractive linear and compact shape.

Cables are internally hidden to give a more clear design. Completely made of die-cast aluminium, with universal EI-002 adapter to fit on the most 3-phases European standard track systems. Top quality electrical components, electronic ballast from main manufacturers in the market and extra pure aluminium reflectors are used to obtain a very high quality items. Completely tilting and turning in every position 355° on axis and 180° on the joining arm. Easy use and relamping maintenance.

Planus

MINI 50

LIGHT BEAM OPTIONS

SEE BULB FEATURES

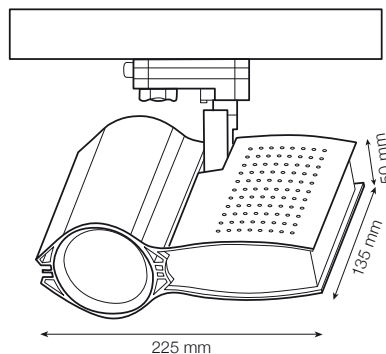

READY TO BE INSTALLED

50 Watt max

MR16 - Base GU 5,3 Halogen

230 Volts - With transformer integrated

IP20 - CE ▽

1,3 kg unit gross weight

AVAILABLE COLOURS

- TEXTURE
- MATT WHITE (ON REQUEST)
- MATT BLACK (ON REQUEST)

Planus

A projector family, for professional applications, ideal for exhibition areas, shop windows, stores, museums.
 "Hi-tech" design with a particularly attractive shape, made of die-cast aluminium.
 Metal halides 35 watt, 70 watt or 150 watt;

Planus

MAXI

LIGHT BEAM OPTIONS



SPOT 5°

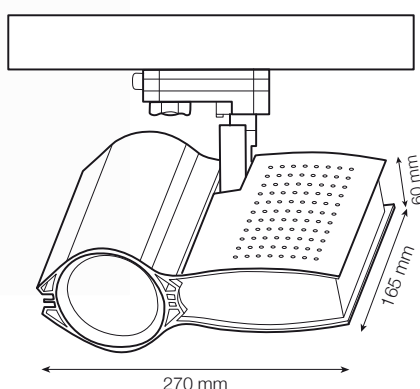



READY TO BE INSTALLED

HIT-CRI - Base G12
 230 Volts electronic or conventional
 IP20 - CE ▽ ⊕
 2,5 kg unit gross weight

PLANUS 35 - 35 Watt max
PLANUS 70 - 70 Watt max
PLANUS 150 - 150 Watt max

AVAILABLE COLOURS

-  TEXTURE
-  MATT WHITE (ON REQUEST)
-  MATT BLACK (ON REQUEST)

A projector family, for professional applications, ideal for exhibition areas, shop windows, stores, museums.
 "Hi-tech" design with a particularly attractive shape, made of die-cast aluminium.
 Completely tilting and turning in every position 355° on axis and 180° on the joining arm.

Planus

LED 10W

LIGHT BEAM OPTIONS



SPOT 10°

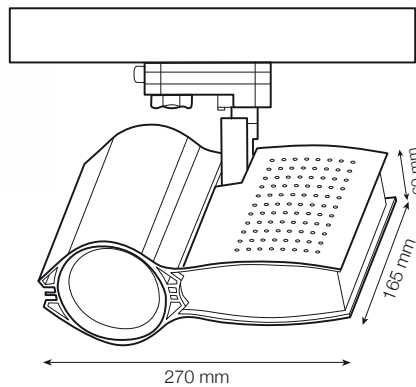

READY TO BE INSTALLED

Led 10W

IP20 - CE ▽ ⊕

2,5 kg unit gross weight

LIGHT COLOUR



COLD WHITE



WARM WHITE

AVAILABLE COLOURS



TEXTURE



MATT WHITE
(ON REQUEST)



MATT BLACK
(ON REQUEST)

Speedster



SPEEDSTER

Speedster

A projector family, for professional applications, ideal for exhibition areas, shop windows, stores, museums.

“Hi-tech” design with a particularly attractive shape, made of die-cast aluminium.

Completely tilting and turning in every position 355° on axis and 180° on the joining arm.

Easy use and maintenance.



Speedster

MINI

LIGHT BEAM OPTIONS



FLOOD 40°

AVAILABLE COLOURS



TEXTURE



MATT WHITE
(ON REQUEST)



MATT BLACK
(ON REQUEST)

READY TO BE INSTALLED

20 Watt max

Metal Halides CDM-TM - PGJ5

IP20 - CE

0,5 kg unit gross weight

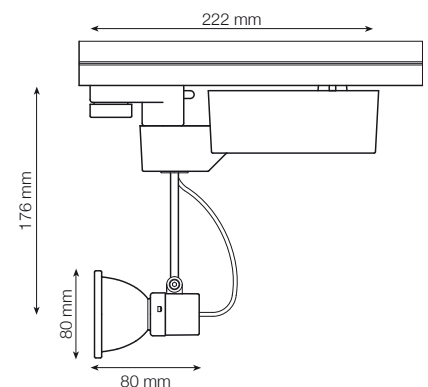

Speedster



A new projector family for professional applications, as shop windows, store, museums and exhibitions areas.

New original design, attractive linear and compact shape.



Speedster

MEDIO

LIGHT BEAM OPTIONS



FLOOD 30°

AVAILABLE COLOURS



TEXTURE



MATT WHITE
(ON REQUEST)



MATT BLACK
(ON REQUEST)

READY TO BE INSTALLED

70 Watt metal halides

HIT-CRI - Base G 8,5

230 Volts

IP20 - CE ▽

0,8 kg unit gross weight

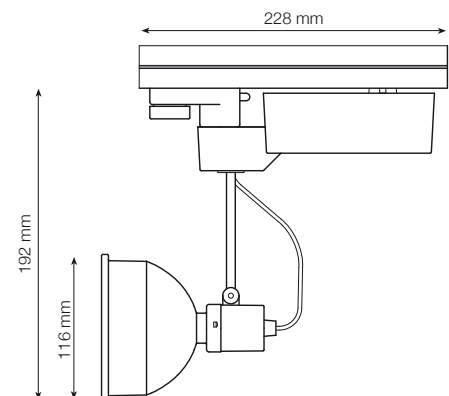

Guarantee terms

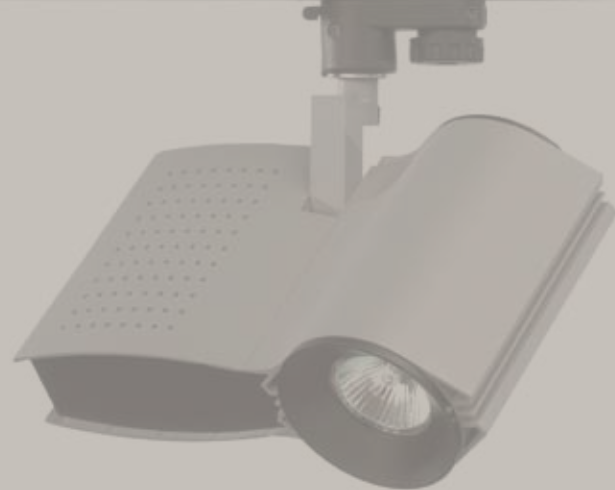

puk ILLUMINAZIONE guarantees the performance of its products only and exclusively in relation to how they are used, their destination and application as explicitly specified.

The guarantee of the products has a 4 year validity starting from the date of delivery to the Purchaser.

Any claims must be forwarded in writing to **puk** ILLUMINAZIONE together with a copy of the

purchase invoice complete with delivery date, description of the fault and number of products that are faulty.

puk ILLUMINAZIONE, according to its indisputable choice will arrange either to repair or replace them within a reasonable period of time from the claim. Returned faulty goods will be accepted by **puk** ILLUMINAZIONE only if previously authorised in writing, correctly forwarded, suitably packed and with transport prepaid.

This guarantee does not cover further expenses sustained by the Purchaser consequent to the faulty condition of the products; in particular **puk** ILLUMINAZIONE will not bear the cost of collecting the faulty products from customers (including cost of dismantling) and forwarding of replacement products to them. Any responsibility on the part of **puk** ILLUMINAZIONE is explicitly excluded in the following cases:

- use, assembly and/or improper or unreasonable maintenance of the products, and/or their correct preservation:
- if damage or bad functioning is caused by work carried out on products without prior written authorisation from **puk** ILLUMINAZIONE (e.g. disassembly, alterations, substitutions, etc.);
- if the quality and performance have been compromised by the addition of accessories not approved by **puk** ILLUMINAZIONE .

This guarantee includes and replaces every other possible responsibility stemming from the products supplied, no matter how it originated: in particular the Purchaser cannot claim damages, reduction in prices or cancellation of the contract. In no case will **puk** ILLUMINAZIONE be responsible for indirect damage or loss of profit.

The Law Court in Monza is the sole competent Court for any disputes.